

Summer 2011

Mastercam® Notes

Customer Newsletter

There's no doubt in anyone's mind that 2009 was a rough year for our industry. We saw many shops (and friends) struggle as reduced orders and suppressed demand created a feedback loop that looked pretty grim. Then the calendar turned and 2010 brought with it a dramatic bounce in the stock market, and signs of life in manufacturing. So what do we think about the rest of 2011? Two words - watchful optimism. Why? Not because of the impressive growth on Wall Street.

Not because of reports of increasing employment or strong year-end consumer spending. While those things are welcome and positive, they're also a bit erratic. Constantly up and down, sometimes dramatically so. No, we're optimistic because in all the chaos and uncertainty of the past two years, our industry—manufacturing—has been plugging away, slowly gaining steam. And manufacturing is the bedrock of a solid economy.



How solid? As of this writing, the Institute for Supply Management index of U.S. manufacturing reports 21 consecutive months of slow, steady growth. The index hovered in the mid- and upper-50's for most of that time, with recent moves into the 60's. And while it's much higher than that in boom times, anything above 50 means growth. Any growth is good, but 21 months of consistent growth—even if it's modest—is something that builds confidence in what's to come.

As we all learned when we were kids, sometimes slow and steady wins the race!

Product Highlights



Mill Feature 2-3
Mastercam's New Port Expert Add-on



Multiaxis Feature 4-5
Mastercam's User Interface



MCFSW Feature 6
Gold Partner Status and Mastercam University Course



Swiss Feature 7
Mastercam Swiss Expert



Router Feature 8-9
James River Millwork Success Story



Art Feature 10
Tracing Low Resolution Bitmaps

MILL

Mastercam's New Port Expert Add-on

Port Expert was created for machining cylinder head ports, but it can be used on any tube-type work. When cutting a port, you want to try to increase air flow, which in turn will provide more horsepower.

Mastercam's new Port Expert application creates accurate, efficient head porting toolpaths on pre-existing port surface or solid data. Port Expert uses a tapered lollipop tool, and has collision checks for the entire tool (shank, arbor, and holder).

There are multiple cutting options available in Port Expert. You can cut the top only, the bottom only, and specify how much stock to leave on the entire port.

The toolpaths use 3-axis machining as far into the port as possible, and then convert automatically to 5-axis motion with minimum tilt. This leaves no fishtails or reverse moves, and smoothly transitions where the toolpaths meet at the middle of the port.

Port Expert provides both roughing and finishing toolpaths to make ports from castings or billet. And, because Port Expert can support unlimited surfaces, the port geometry can be made of multiple surfaces that are stitched together.

After programming the toolpaths, you can simulate the cutting process without leaving your desk.

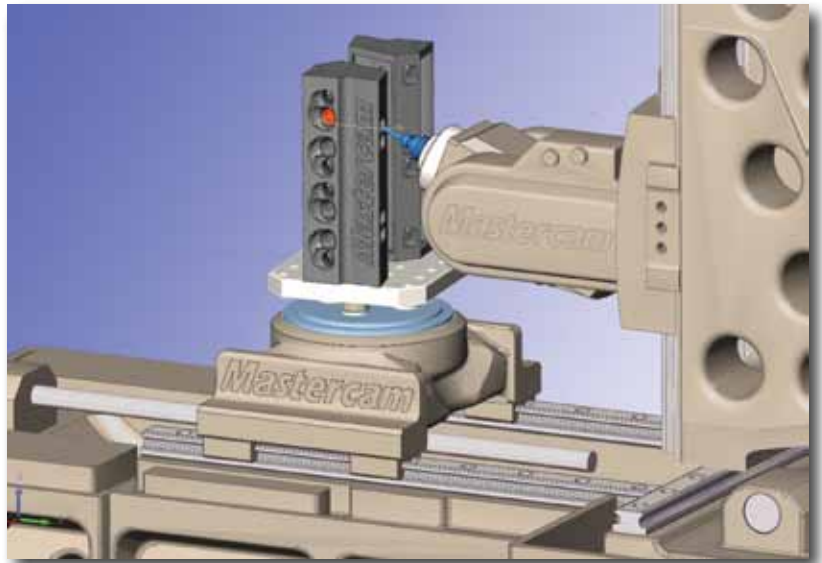

Mastercam generates 5-axis code that can run any CNC machine. The simulation proceeds step by step through the toolpath, even showing you the motion used in transition at the middle of the port.

Simulation is a safe and cost effective way of proving out your toolpath, and it can also help assist you with designing better fixtures for your work.

With Mastercam Port Expert, you will have an edge over your competition! We gave a sneak-peek of the software at the 2010 Performance Racing Industry trade show. Please visit <http://tinyurl.com/portexpert> to see the reactions of experts who saw and used the software.

Note: Port Expert is a Mastercam add-on that must be purchased separately. You must own Mill Level 3 or Router Pro to purchase the add-on, but you do not need to own the Multiaxis add-on. ☒

MOLDPLUS CATIA TRANSLATOR

Import CATIA V5 data
- MBD (GD&T) data
- CATIA V5 feature tree

Import & export CATIA V4 data

MOLDPLUS www.moldplus.com

The Port Expert Process

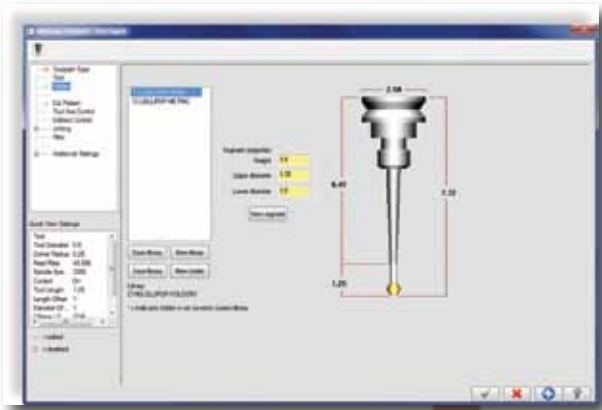

1. The first step is to pick your tool.



4. Collision control - you can set near miss tolerances for every part of the tool.



2. Second, you select the desired cut pattern.



5. Select the method of rapid tool motions.

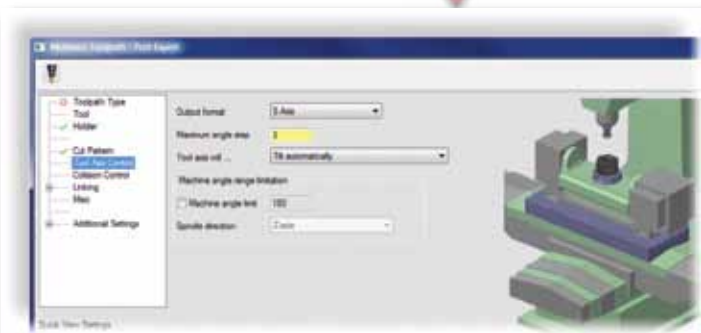

3. The tool axis control will be automatic.



6. Run full machine simulation before committing to a machine.



MULTIAXIS

Mastercam's User Interface

All multiaxis toolpaths now share a common user interface (UI). The intent of the new UI is consistent workflow regardless of which multiaxis toolpath type you are using. Ease of use was one of the main considerations during the design of this new UI.



The Classic toolpath type family group.

You will use the following process for all multiaxis toolpaths:

- Select a **Toolpath Type Group** based on calculation
- Select a **Toolpath Type** available from each group
- Select a **Tool**
- Select a **Holder**
- Select a **Cut Pattern** to use
- Select a **Tool Axis Control** method
- Select a **Collision Control** method
- Select **Linking** options
- Select a **Roughing** method (if it is a roughing operation)
- Set any **Additional Settings** that are necessary

There are six major Toolpath Type family groups (Classic, Wireframe, Surface/Solid, Drill/ Circle Mill, Convert to 5x, and Custom App).

You begin by selecting a toolpath family.

The Toolpath Type dialog pages all have four major areas:

1. Tree-style Dialog.
2. Quick View Settings.
3. Parameter Fields where geometry and functions are selected.
4. Dynamic Image Area where the images dynamically change as you navigate through the Parameter Settings area. These images are designed to give you an instant visual of the selection you are about to make or edit.





Next, you proceed through the branches of the tree structure until all necessary parameters have been set. The tree structure changes based on toolpath family and type selections. Additional settings are available in the tree, although they are generally left alone for multiaxis toolpaths.

The tree is laid out in the logical order of setting your toolpath parameters. Simply advance along the tree structure, choosing your options and setting your parameters along the way, to create the desired multiaxis toolpath.

You may click on the parameters of a toolpath in the Operations Manager to edit the existing parameters, but you cannot change the toolpath type or family.

For more information on the new multiaxis UI, or to walk through how to create a multiaxis toolpath, please view the *What's New* PDF that is available from the Mastercam X5 What's New dialog box, (and from the Mastercam X5 Help menu).

And, a new Mastercam University™ course is now available for Multiaxis training. For more information, please visit www.mastercamu.com. ☒



The Surface/Solid toolpath type family group.



The Wireframe toolpath type family group.



Mastercam for SolidWorks

Mastercam® for SolidWorks® Awarded Gold Partner Status

Mastercam for SolidWorks was recently awarded Certified Gold Partner status and supports SolidWorks® 3D CAD software.

As a SolidWorks Certified Gold Partner Product, Mastercam for SolidWorks allows users to program their parts directly in SolidWorks, using Mastercam's vast array of toolpaths. This combines the best in CAD with the best in CAM, all without leaving the SolidWorks interface.

Designers, engineers, and machinists use Mastercam for SolidWorks to program their toolpaths after they have finished designing in SolidWorks. The toolpaths are applied directly to the SolidWorks model in their native environment.

"With our toolpaths running directly in the SolidWorks environment, our users will feel comfortable programming their parts, just as if they were in standard Mastercam," says Ben Mund, Marketing Manager. ☒



Mastercam for SolidWorks Course Available

We also have a course specifically for Mastercam for SolidWorks available from Mastercam University. Inside SolidWorks, you can access 2D and 3D toolpath strategies along with high speed toolpaths and fully automated Feature Based Machining for milling and drilling features.

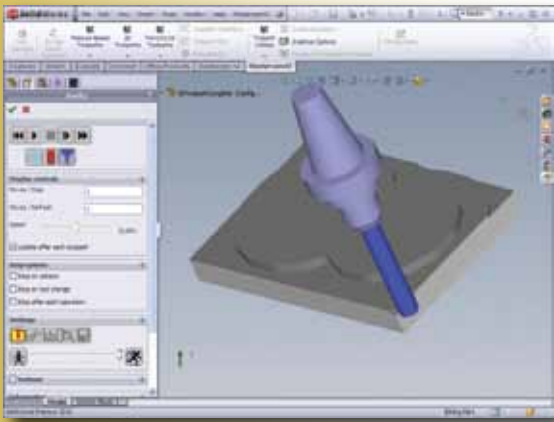

This course consists of six modules:

- **Getting Started** walks you through preparing Mastercam for SolidWorks and the part file.
- **Design for Toolpaths** uses SolidWorks to create geometry, emphasizing geometric and dimensional constraints for controlling toolpaths.
- **Essential Machining–Parts** teaches toolpath strategies, creating toolpaths on parts, and toolpath control.
- **Essential Machining–Assemblies** teaches toolpath strategies, creating toolpaths as assemblies, and toolpath control.
- **FBM Toolpath** introduces Feature Based Machining to automatically program pockets, contours, and drilling routines.
- **2D High Speed Toolpaths** presents HST toolpath techniques for shorter cycle time and better part finish.

For more information on Mastercam for SolidWorks, please view the comprehensive PDF tutorial that is installed with the software. For more information on the Mastercam University course, please visit www.mastercamu.com. ☒

SWISS

Mastercam Swiss Expert

CNC Software is proud to announce that we have acquired well-respected Swiss Machining software SylvieXpert. Developed in Switzerland for Swiss machines by experts in the Jura region of Switzerland, we've been refining and adapting it since the acquisition.

The SylvieXpert product (now known as Mastercam Swiss Expert) popular with watch-making, medical device, dental, automotive, and electronics companies—all known for the requirement of very small yet high quality parts—was developed in the region of Switzerland where the Swiss-style machine was invented.

Mastercam Swiss Expert is known for its support of an unlimited number of axes and channels, and for full machine simulation of the machining process. The product was developed for the Swiss machines of today, with an eye toward the more complex machines of tomorrow.

Mark Summers, President of CNC Software, says "CNC Software is excited to have acquired the SylvieXpert software product. It complements the broad offering of Mastercam CAD/CAM solutions we have available to the market. Our plan is to continue to develop, market, and support this product."

Development is currently underway to complete the next release, Mastercam Swiss Expert 2011, which should be available in the next several months. Watch for more information on Swiss Expert in upcoming issues of Mastercam Notes. ☒

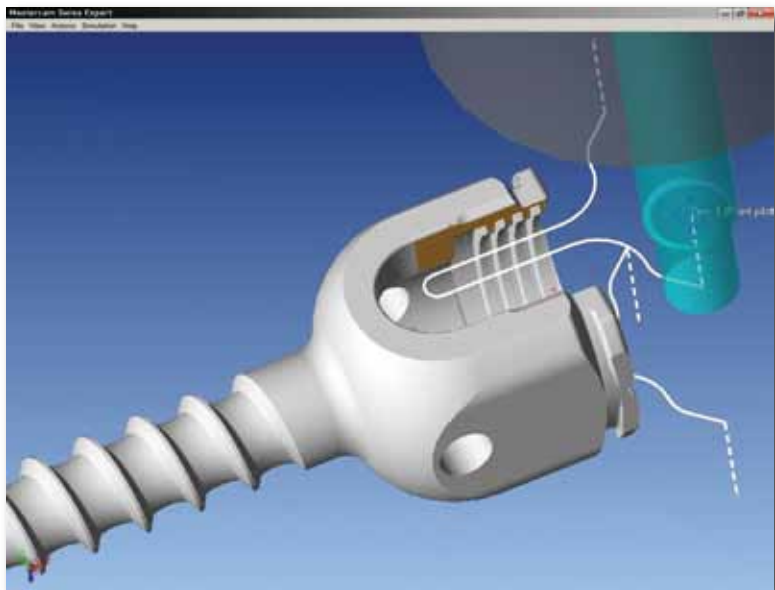
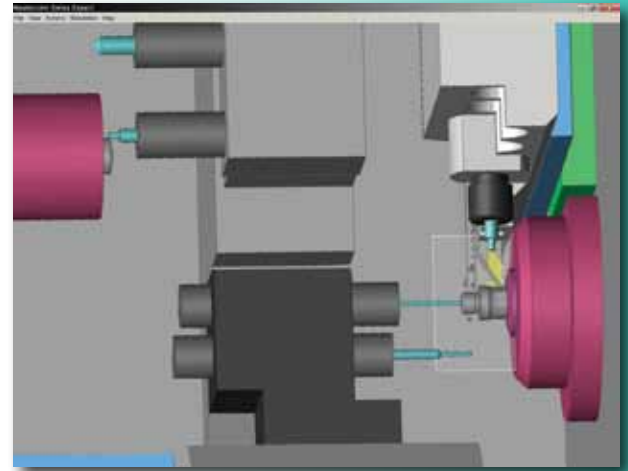

JUST PUBLISHED ... THE LATEST IN MASTERCAM!



Valentino, 2011, 800pgs,
CD, 3-423-5, \$74.95

INCLUDES NEW MATERIAL ON ...

Machining with 2D High Speed Toolpaths • 2D high speed dynamic toolpaths: area mill, rest mill, core mill, contour mill • Executing 2D Feature Based Machining(FBM) on Solid Models.

COMES WITH A MASTERCAM X5 DEMO!

GO TO WWW.INDUSTRIALPRESS.COM TO ORDER OR FOR MORE INFORMATION. TO RECEIVE A 25% DISCOUNT USE SPECIAL OFFER CODE MN-11*.

*Offer Expires 5/31/11.



INDUSTRIAL PRESS INC.
www.industrialpress.com



ROUTER

Up-to-Speed Over a Weekend—James River Millwork



Early in 2008, Jess Coleman, owner of James River Millwork, located in Lynchburg, Virginia, decided that he would improve the scope and productivity of his five person millworks business by purchasing a 3-axis router and CAM software. There were only a few glitches in his plan. He had no experience at all with CAM, he didn't have any free time to learn how to use it, and he didn't have a lot of money to spend. Aside from those little issues, all systems were "go".

The Challenge: James River Millwork needed to expand their shop's capabilities, improve their scope and productivity, and shorten turnaround times.

The Solution: Mastercam Router

Benefits of Mastercam:

- Mastercam's user interface was very familiar to Coleman, and it is one of the most intuitive software packages they have ever used.
- Mastercam's local Reseller was close to the shop, and was familiar with the router they were using. They got them up-to-speed using the software on the shop floor, and helped them out whenever they were stuck.
- Mastercam's automatic nesting capabilities are a money-saver.
- The software has allowed them to compete in new business areas, like cabinetry.

Project Details: To conserve on cash, Jess located an eight year old Atlas router with a 5' x 10' moving table that was in good condition. After making that purchase, Coleman did something that seemed to be counter-intuitive. He purchased a CAM software package that was almost as expensive as his CNC router. However, in retrospect, that decision made the integration of a new manufacturing capability into his business practically painless.

Before making a decision on what CAM software to purchase, Coleman experimented with the software that originally came with his router. Using some programs downloaded from the Internet, he could put his machine through all the motions. With that little experiment he could tell that the time spent manually writing programs, even in the latest version of that program, would negate the benefits of automatically manufacturing parts.

Then he asked around and found out what other people were using. After taking a closer look at one other package, he chose the entry-level version of Mastercam Router.

Coleman said, "My background is in computers and computer engineering and I am an experienced AutoCAD user. So the software's windows-based user interface looked very familiar to me. On top of that, Mastercam is one of the most intuitive software programs I have ever used."

In this case, the software had two other things going for it. The local Reseller was located only a mile from Coleman's shop. The Reseller was also familiar with the Atlas router and would be able to provide a postprocessor for the software that would work seamlessly with the machine's Fanuc controller.

The Reseller spent the better part of a day at the shop setting up the router and showing Coleman how to use it. Then Coleman spent most of the weekend getting familiar with his new tool and the basic software functions. And that was it. He now had CNC router capabilities.

Since that time, Coleman has not gone back for formal training in using the software, although he knows it is available. Every time a new capability is required, he figures it out for himself. If he gets



stuck, which is not often, Coleman picks up the phone and calls the Reseller who will either give him a few pointers on the spot or come over and show him what needs to be done.

At present, the router is used on an as-needed basis that amounts to about eight hours a week. With Mastercam's ATP (automatic toolpathing) capabilities, it takes Coleman almost no time at all to import a drawing from AutoCAD and create the cutting program. Now that he is more familiar with the program, Coleman believes that its drafting capabilities are comparable to AutoCAD, and he is creating some of his drawings directly in Mastercam.

Does it even pay to have a CNC router that you only use 8 hours a week? "Absolutely," he said. "We do work for other shops that don't have routers and we will cut parts and templates for them. We get tons of requests for stuff that needs a real quick turn-around. Often it's somebody who comes in and needs something right away. So I will sit down and draw something up and send it to the router. I rarely have to start from scratch. I can usually pull up a similar piece and use most of the settings I used before."

In addition to making his own business more productive and opening up opportunities to make parts for other shops, the new software and router make it possible for Coleman to compete in a totally new business area, cabinetry. These tools allow James River Millwork to efficiently manufacture a lot of different parts of various sizes quickly.

In addition, Mastercam's automatic nesting capabilities are a real money saver. In one case, he did eight sets of kitchen cabinets that would have required 60 sheets of prefinished plywood if it were done on a table saw. With nesting, all of the parts were produced using just 50 sheets. At

\$50 per sheet that amounted to a savings of \$500 on this one job, not to mention the labor savings attributable to CNC manufacturing.

"We did very little cabinet work before, just because we weren't set up and efficient at it. Now we can compete a lot more easily because this capability takes so much of the labor out of it," Coleman said.

He anticipates the utilization of his router and CAM software to grow substantially in the months ahead. Coleman said he's looking forward to it because "it's my cheapest employee." ❌

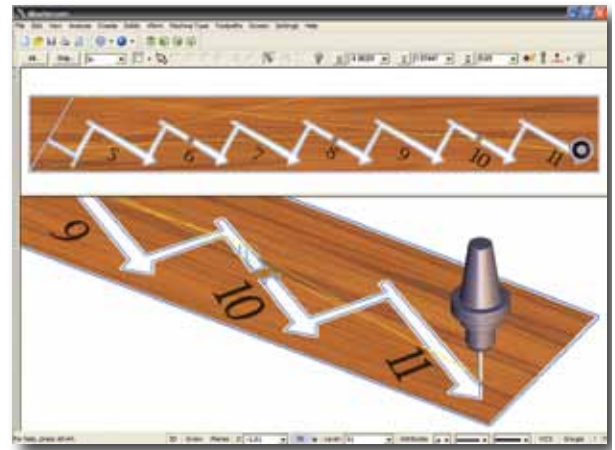

Automated stair stringer creation.





ART

Tracing Low Resolution Bitmaps with Image to Surface Function

If you are having trouble getting a good trace (a Raster to Vector translation) on a low resolution bitmap, we have a new strategy for you to try. Using Mastercam Art, we will convert this image to a surface, we will smooth it out, and then slice the surface at a Z-depth to get a better trace. **Note:** This strategy works best on low resolution black and white images.

Let's run through this process using the graphic at the right. It is a low resolution image that is rather chunky, and we will process it with this new technique to get a good trace. Here are the steps:

1. Convert the image to a surface. Select **Create, Art Base Surface, From Image**. In the Convert to Grayscale dialog, check **Maximize Contrast** and **Make Negative**, and then click the green check mark. **Note:** In this image, we want the black lines to be raised. In this function, the whiter it is, the higher it is.
2. In the Import Image Setting dialog, set the height range to **0.080**, and then accept the changes.
3. Create a rectangle around the surface.
4. Select **Smooth** and then select the rectangle.
5. Input Smoothing Radius at **0.045**.
6. Select **Trace Art Model at Z Depth** and then set depth of the slice for **0.003**. This is the drop down under **Trace Image\ Rast2Vec**. Now the trace is complete.

The output is much cleaner and has a smoother looking result than compared to using Trace Image.

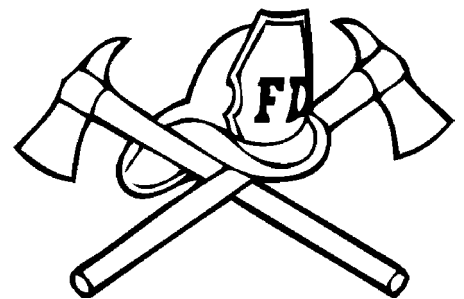

Original Bitmap.

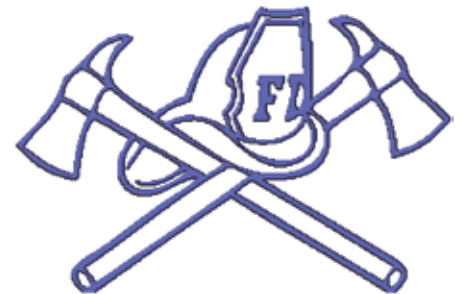

From Image Translation.



Smoothed Image.

Since each image is different, so are the processes you use to convert them. What might work for one image may not be the best choice for the next raster image you try.

This process demonstrated here works very well for grayscale (16 shades up to 256), black and white, low resolution bitmaps.

For a more detailed explanation of how to work through this process, please visit www.mastercam.com/art/techtip.pdf. ☒

Get Integrated PSE!

Post-processing
Simulation
*Emulation

*for G-Code Verification

Supports Multi-Axis
Mill & Mill / Turns!



icam.com/Mastercam

WIRE

4-Axis Direct Wirepath Improvements and More

The 4-axis Direct wirepath now accommodates more types of geometry and creates smoother motion in Mastercam X5 MU1 Wire. Some of the improvements include:

- Support for splines (broken into linear moves by the linearization tolerance).
- Support for line/arc motion pairs (broken into 4-axis Direct linear moves by the linearization tolerance).
- If a clockwise arc is paired with a counterclockwise arc, this section of the toolpath will be output in 4-axis Direct linear moves so any wire machine can handle it. Most wire machines will not handle a clockwise move in one plane paired with a counterclockwise move in the other plane. So in previous versions, such moves would have forced you to use the 4-axis Taper method (all linear moves) instead.
- Chained geometry no longer needs the same number of entities between branch lines. If there are a different number of entities between branch lines in the XY and UV motion, the toolpath will break up both the XY and UV into the same number of linear moves. The toolpath will also always hit the endpoints of all entities and stay within the linearization tolerance of the arc/spline geometry.

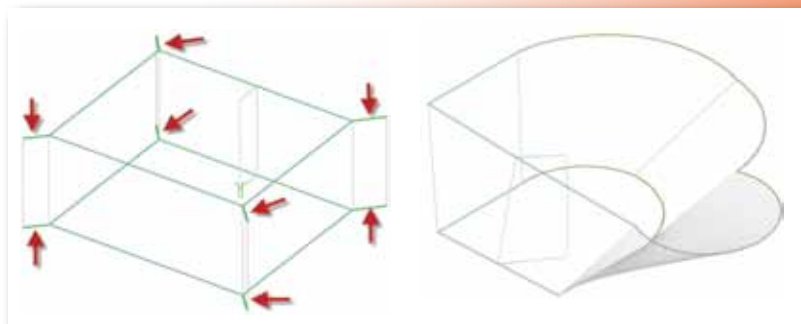

New 4-axis Tab Stop Location Options

Mastercam Wire adds the ability in 4-axis wirepaths to set the location of a tab stop by a specified distance from the tab end. This new option allows you to cut partially through the specified tab, do a stop, secure the slug, and then continue on to complete the cut-off. In addition, you can now specify up to three stops for a tab: before, at a distance on the tab, and after the tab has been cut off.

Window Chaining Geometry with Relief Cuts

Mastercam Wire now supports window chaining of relief cuts in your material workpiece. As shown in the image above, Mastercam Wire will recognize these single lines as relief cuts and chain them as such. The wire will travel up those lines and back down and continue on around the closed geometry.

Several conditions must be met in order for Mastercam to recognize these relief lines when window chaining:

- The part must be a closed contour—open chains are not supported.
- You must create a Contour wirepath.
- The relief lines have to be single line, arc, or spline entities placed at the endpoints of the entities in the closed chain. If a single relief line is placed at a midpoint, it will be recognized as a separate chain. ☒



Educational News

Kennedy High School's Chopper Class



Students from Kennedy High School proudly standing by their bike named "Stretch."



In March, we featured a chopper named "Stretch" in our booth at the International Technology and Engineering Educators Association show in Minneapolis. Stretch won 3rd place in Open Class at the 2010 Donnie Smith Invitational

and was featured in the invite-only premiere Sturgis bike show put on by world-famous motorcycle photographer Michael Lichter. Many were surprised to hear that the chopper was fabricated by high school students from Kennedy High School (Bloomington, MN). One of the most common comments we heard from attendees was, "I wish they had had a program like this when I was in high school!"

Since instructor Kevin Baas started the program in 2003 as an extracurricular activity, it has blossomed into two for-credit classes—motorcycle technology and manufacturing. Although statistics aren't available, approximately 150-200 students pass through the program each year, with many going on to college or starting careers with what they learned in class. A number of those students have earned scholarships through their work with the chopper project.

The Kennedy High School Chopper Project teaches design, math, science, CAD, computer graphics, and more. Even more importantly, all of these skills and

more are taught as part of a project that students are excited about, proud of, and are willing to go the extra mile for. While they typically have three bikes going at any one time, they strive to finish at least one each year. Over the years, these choppers have won over 25 awards at various events.

Incredibly, Baas manages to do all of this with an extremely limited budget. The entire program is supported solely through the generosity of sponsors and very active fundraising. Baas is well-respected in the chopper world, and has used a lot of his connections to help his students excel. It works well for both the students and the participating businesses. The businesses get the positive public exposure while being able to deduct their donations and helping to shape the next generation of employees.

Without the support of these businesses, this exceptional program wouldn't be possible. The next generation of manufacturing professionals needs you. Seek out local programs that your business can help. It doesn't always have to be financial. Donate equipment when you upgrade, donate your time and expertise, invite students who may not have considered a manufacturing career in for job shadowing.

Contact your local Mastercam Reseller to find out how you can help. To locate contact information for your Reseller, go to:

www.mastercam.com/Resellers.

For more information on the Kennedy High School Chopper Class go to:

<http://www.kennedychopperclass.com/>.

If you are interested in purchasing Stretch, it is for sale for \$15,000. All proceeds will be rolled straight back into the program. ☒



2011 Wildest Parts Contest

Make Something Wild!
Think outside the box and cut outside the lines.

The challenge is simple...create a bold, original item using Mastercam.

Mastercam's Wildest Parts competition challenges students to design and make something that is wild! We are looking for parts that either haven't been done before, or have never been done that way before. The challenge is for students to break the mold, think outside the box, and cut outside the lines.

First and foremost, we are looking for an eye-catching piece. But, it doesn't have to be the most complex part. We have designed a display case for our show booths specifically for the Wildest Parts Competition. This case travels to the top educational shows, and people from all over the country stop to look at the parts. We are looking for parts that will demonstrate the many impressive and creative parts that can be made with Mastercam.

The winner in each of the secondary and postsecondary categories will win a \$1,000 scholarship. Second and third place prizes are \$250 and \$75 scholarships, respectively. Each entrant will receive a Mastercam shirt. ☒

For more information on the Wildest Parts competition, including judging, rules, and entry form, please visit www.mastercam.com/wildestparts.

LEARN Mastercam TODAY!
Books with Videos
Online Courses
Learning Mastercam with camInstructor is quick, easy and affordable!

"The camInstructor online course was great. It helped me land a job quickly when I was unemployed. I'm now using Mastercam on a daily basis at my job."
- Ken Johns, CNC Programmer

camInstructor
877.873.6867 www.camInstructor.com

Mastercam
Tips For Manufacturing **Video Training**

"Why Read The Book When You Can See The Movie!"

- Complete "Step By Step" training
- No Subscription / No Expiration
- Use it on any PC / No Installation
- Great for new, or, experienced users
- Learn at your own pace, on your time
- Great for reviewing a single process
- Includes DXF, DWG & Solid Models

Postprocessors & On-Site Training Available.
Now Located in Mesa, Arizona

www.TipsForCadCam.com or...
www.TipsForManufacturing.com
Questions? Call Us at... (480)-986-9528



OTHER NEWS

Have You Checked Out Mastercam University™ Yet?



Mastercam University is dedicated to training you how to use Mastercam. After completing the Mastercam University training, you will be able to work more efficiently and produce more parts faster.

Mastercam University is online video training that lets you learn at your own pace. You will benefit from the knowledge of expert corporate trainers that bring their extensive industrial experience and Mastercam mastery to each lesson. Courseware is delivered in a progressive order using movies to demonstrate proven industrial techniques.

Mastercam University uses short concise videos that are reinforced with practice drawings and sample parts for you to complete, including both metric and inch part files. The videos are divided into a series of simple steps, and each video covers a specific point or technique. You can go back and review the videos as many times as you like.

A subscription to a class includes 12 weeks of lessons. After completing a class, you can download a Certificate of Completion.

If you are currently a Mastercam Maintenance customer, you should take advantage of the free Mastercam Maintenance class to get you up to speed with X5 and to learn some of the new features that you might not be aware of.

If you are a teacher new to Mastercam University and are not quite sure how to incorporate it into your classroom, please check out the video on our Web site explaining how you can introduce Mastercam U to your students and integrate it into your curriculum.

For more information on Mastercam University, or to see a sample video, please visit www.mastercamu.com. ☒



New Mastercam YouTube Channel

Attention Mastercam video subscribers...

We wanted to let you know that Mastercam has moved to a brand new YouTube channel.

Please check us out and re-subscribe at www.youtube.com/mastercamcadcam. As of now, our old YouTube channel will no longer be updated with new videos.

New Mastercam University Course Now Available

We are pleased to announce the addition of a new course on Mastercam University—Multiaxis Curve, Drill, and Circle Mill.

The Multiaxis Curve, Drill, and Circle Mill course starts out with an overview of some common 5-axis machines. It covers X, Y, Z, a, b, and c-axis combinations and machine zero positions. The course also goes into detail on tool axis control, and geometry creation for tool axis control.

Extensive training is also offered on how to use the Curve, Drill, and Circle Mill toolpaths.

Machine Simulation is used to illustrate the advantages of seeing your multiaxis part being machined virtually. There are multiple lessons on how to create and manipulate planes for multiaxis machining.

And, as a bonus, there is a complete module on 4th Axis Rotary Machining (including Axis substitution, Axis positioning, and Rotary Surface Machining). ☒

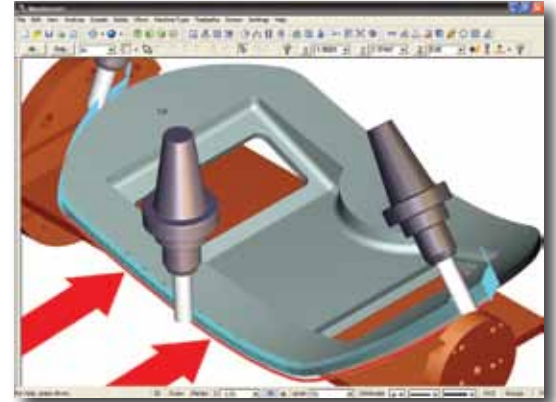

The Multiaxis Curve, Drill, and Circle Mill course is now available on Mastercam University.

New Promotion for Mastercam University Has Begun



We are offering a new Mastercam University promotion!

Starting June 1, and ending August 31, 2011, if you buy any Mastercam University course, you can get a second course half off.

You can choose from the following courses:

- Mill Design & Toolpaths
- Advanced Mill Design & Toolpaths
- Lathe Design & Toolpaths
- Mastercam for SolidWorks
- Principles of Machining
- Mastercam Transition (V9 to X5)
- Multiaxis Curve, Drill, and Circle Mill

Please note: Both classes will need to be ordered at the same time, and both classes must be under the same company's e-mail address (although the person's name can be different). This promotion is open to Industrial users only. ☒



OTHER NEWS

Find Out What Mastercam's Business Partners Can Do For You



Mastercam has teamed up with some of the manufacturing industries' top players. How can this help you? Many of Mastercam's business partners can help you boost your bottom line by offering new software tools, shop-proven hardware, powerful learning tools, and so much more.

Whether you are looking for hardware, software add-ons, or training options, chances are Mastercam's business partners have something for you. Below are some examples of Mastercam's partner products:

CAD Products – Specialty modeling tools to speed your CAD designing

CAM Products – Programming extras to boost your shop's output

Learning Tools – Resources to get you up to speed with Mastercam

Verification – More ways to check your work

Hardware Partners – Providing hardware solutions for Mastercam

For more information on Mastercam's Business Partners, please visit www.mastercam.com/Partners. And, keep your eyes open for the digital newsletter that will be showcasing Mastercam's third-party products. This newsletter will focus solely on Mastercam business partners and the products they have to offer you. ☒



Mastercam is Autodesk Inventor 2012 Certified

Mastercam X5 has been certified for Autodesk Inventor 2012 3D mechanical design software under the Autodesk Inventor Certified Applications Program. To be certified, the product must meet certain guidelines and demonstrate a high level of quality as well as compatibility with Autodesk Inventor software.

Gary Hargreaves, Director of Business Development, says "We are very happy to be certified for Autodesk Inventor 2012. Many Mastercam customers receive Inventor files, so both communities can be assured of the seamless integration between our two products."

Mastercam X5 has a direct add-in for Autodesk Inventor, a great way to boost productivity. Free to the Mastercam and Autodesk communities, Mastercam Direct enables users to open a model in Mastercam while in an Inventor session, and then update toolpaths to reflect changes to the model. Mastercam X5 is able to read in native Inventor files (.IPT and .IAM) for design purposes and toolpath generation.

Mastercam Direct for Inventor is available at no charge from www.mastercam.com or through your local Mastercam Reseller. ☒

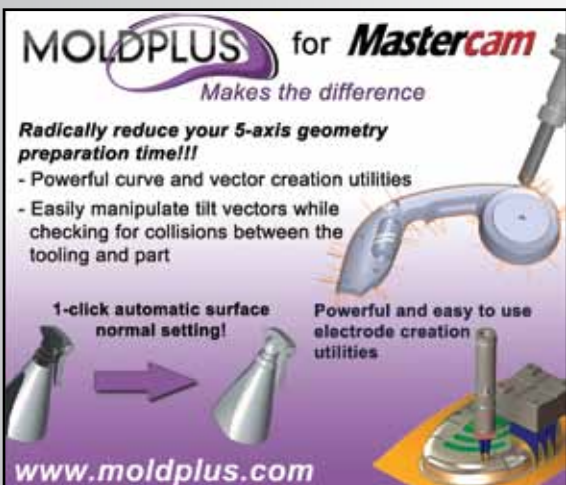



Agile CAM Improves Manufacturing Versatility

Northstar Aerospace (Duluth, MN) decided to upgrade its CAM capabilities with software that would allow the company to automate CNC programming generation to the greatest extent possible, establish a viable manufacturing strategy for parts in a virtual environment rather than on-machine, and resolve potential problems before the part was set up for manufacturing.

The Challenge: Make the transition from being strictly an aerospace shop to an agile, diversified manufacturer capable of handling projects of any size.

The Solution: Mastercam software

Benefits of Mastercam:

- Mastercam is easy to learn and use
- Mastercam gives you the ability to control toolpaths at any level
- Ability to resolve potential CNC manufacturing problems in a computer-simulated environment
- Working from Parasolid models dramatically reduces programming time and prototype manufacturing lead times

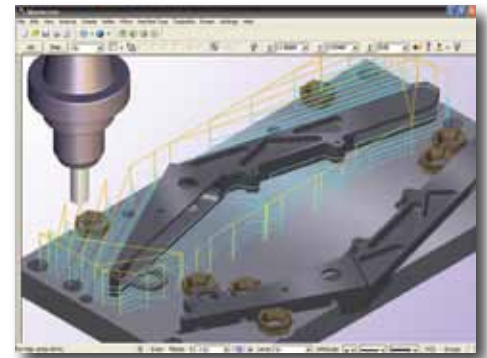

Northstar chose Mastercam for their CAM software.

Project Details:

The company evaluated several CAM software alternatives and decided on Mastercam with Solids. Don Winberg, Director of Manufacturing for Northstar, explained that Mastercam with Solids fit in very well at Northstar because their parts can be so irregular. They can import the solid model directly from whatever CAD program the customer is using and generate the toolpaths automatically. On the other hand, in the places where tight control is needed, the programmer can go in randomly and edit the toolpath down to the point, if necessary.

Mastercam allowed it to quickly land a massive prototyping job making nearly 300 complex, irregularly shaped parts and delivering them in a matter of months. The company's main programmer, Michael Peterson said, "The idea was to have our customer receive parts as fast as possible but everything had to be right. By importing the solid model we could be sure we would not miss anything and the part would replicate the CAD model every time."

To handle the tsunami of parts coming its way, Northstar bought a second Mastercam seat and trained several others to bring in CAD models and automatically generate initial toolpaths. A number of Mastercam features were instrumental in expediting the programming, minimizing machining time, and assuring that there were no programming errors that would result in scrap. These included High Speed Roughing, Work Coordinates, using Mastercam's CAD capabilities to quickly design tooling and fixturing, Backplot, and Verify to assure a crash-free manufacturing process that removes just the right amount of material everywhere on the part. Winberg said, "The big thing we have learned from this is that we can use Mastercam to shorten our lead times and drive out engineering costs. So everything we do can be profitable, no matter what the volume. Being able to diversify our customer base has allowed us to keep our people and equipment busier, and our project volume on an upward trajectory. ☒



OTHER NEWS

Medical Job Shop Startup Balances Talent and Technology

Steven Hicks, General Manager of Thorn Industries (Springfield, MA), says the not-so-secret secret of this medical part job shop's success has been to specialize in one thing and do it really well. His company only hires experienced staff with multiple skills. The company invests in the best manufacturing technology it can afford but avoids what it considers to be "bells and whistles". This approach has made it possible to stretch their technology acquisition budget as far as it can possibly go.

The Challenge: Improve CNC programming efficiency for sophisticated medical parts manufacturing, while preserving capital to invest in more equipment.

The Solution: Mastercam Mill

Benefits of Mastercam:

- Mastercam is easy to use
- Many experienced users are proficient in Mastercam
- You can make precise adjustments to toolpaths to meet demanding customer expectations
- One base-level software package efficiently creates toolpaths for many advanced machines

to tackle any combination of projects that come up during a given day.

For a small and relatively new shop, its equipment acquisitions have been impressive. Thorn's manufacturing technologies include 7-axis screw machining, 5-axis milling, 5-axis wire EDM, CNC turning, 4-axis laser marking/engraving, welding, passivation, polishing, and assembly. The company is certified to ISO-13485 and ISO-9001.

For the longest time, Thorn resisted acquiring a CAM system because all of its operators were experienced hand coders, and because the dollars that would be used to invest in CAM would initially subtract from dollars available for other important investments.

As for CAM, in 2008, the company relented and purchased a 2½D seat of Mastercam. The company considered several options. There were a number of products that offered more features than the basic level of Mastercam. But, within these feature sets, the alternative products did not allow programmers to modify the toolpaths to do exactly what the programmer wanted in critical areas of the part. In addition, all of the operators had used Mastercam at other companies and were immediately comfortable with it.

Hicks said, "When we started to evaluate Mastercam, we discovered that the base-level product is capable of automating the vast majority of the things we did when we were hand coding." So, Thorn began by acquiring one basic single seat of Mastercam to program all of its sophisticated CNC equipment, including its three Tsugami Swiss machines.

"You just have to know how to orient Mastercam to the appropriate geometry and it will do the rest. You need to know where you are. We build a model in SolidWorks®, rotate that thing around, bring it into



Thorn Industries had to improve programming efficiency for sophisticated medical parts.

Project Details:

Thorn's organization is lean and flat. At any given time, four of the five people are engaged in programming, setting up, and operating CNC equipment. The company feels that a diversity of skills is essential, so that as a team, the staff is able



Mastercam, and we are exactly where we need to be to create the toolpaths. We do some really intricate 5-axis work using just our standard CAM package," said Hicks.

Hicks said the switch from hand coding to using Mastercam has resulted in an astounding 50% improvement in both programming and manufacturing productivity. A large proportion of the machining cycle reductions has come about by using computer simulation and other features in Mastercam to eliminate "air cutting" time.

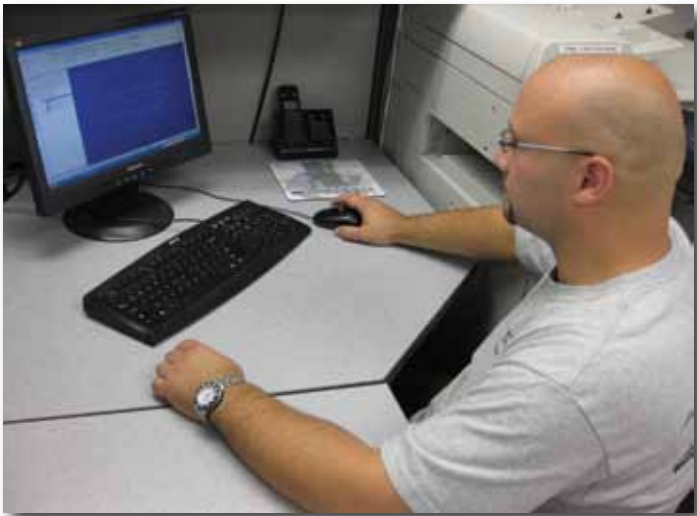

Thorn Industries does intricate 5-axis work using Mastercam.



Today, Thorn has one programmer and most of the CAM work is flooded through him. So, only one seat of Mastercam is needed for the time being. If need be, there are four others (including Hicks and his father) who can jump on Mastercam and create a program. At present, the company is "pounding out" about 20 CNC programs a week on this system. They are fairly evenly balanced between mill, lathe, wire EDM, and Swiss machines.

In the future, Hicks anticipates moving into a full-blown 5-axis version of the CAM software. For now, the basic package gives them a solid foundation for everything they need to do. ☒

ProDrill for *Mastercam*
Advanced feature based drilling for surface and Solid models!



Rapid return on investment!

Analyze drill forms and generate machining processes with blinding speed!

Coming soon : **ProDrill V4 !!!**

MOLDPLUS www.moldplus.com

Mastercam Promotion at iMastercamstore.com

We are pleased to announce several new items now available at iMastercamstore.com. We have two fantastic computer bag options: a backpack from OGIO and a briefcase from Case Logic. Both are high quality, from well-regarded companies. They are black with Mastercam embroidered in white and red.

By popular demand, we have added two styles of Mastercam banners. One is black with Mastercam in white and red, while the other has a colorful background of real-world parts with the Mastercam logo in black and red. All are made with Eco-friendly artists canvas and printed with soy and water based inks. You will find six and eight foot sizes.

And, if your company has users working different shifts that share the same Mastercam license, you can now order additional Mastercam X5 Quick Reference Cards.

If you are like us, Summer cannot come soon enough. While waiting for it to arrive, we are offering 15% off your entire order, excluding shipping and tax. Just enter promotion code **ENWSJULY11** during checkout. One promotion code accepted per order. Code expires **July 31, 2011**. If you have any questions, please email imastercamstore@mastercam.com.



CNC Software, Inc.
Corporate Headquarters
671 Old Post Road
Tolland, CT 06084 USA
(860) 875-5006
mcinfo@mastercam.com
www.mastercam.com

Educational Division
5717 Wollochet Dr. NW
Gig Harbor, WA 98335
(253) 858-6677
info@mastercamedu.com

Mastercam® and Mastercam University™ are registered trademarks of CNC Software, Inc. ©Copyright 1983-2011. All rights reserved. SolidWorks is a registered trademark of DS SolidWorks Corporation. Other trademarks are property of their respective owners.